

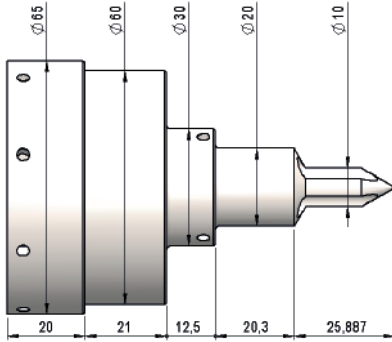



SERIE STR $\varnothing 10$ mm

Trascinatore idraulico / pneumatico
 Hydraulic / Pneumatic face driver



TESTINA / Head	STR003.002.12*
----------------	----------------

		
RANELLA / Nut	STR003.004.02*	
PINZA / Clamp	STR003.005.02*	
PISTONE / Piston	Vedi sotto / See below	

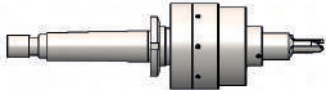
C.M. 3 / Morse taper 3	
	
L. tot.	242
CORPO / Body	STR003.001.01*
GHIERA / Ring	GHKM6
PISTONE / Piston	STR003.003.02*
CODICE ASSIEME / Code	STR003.000.10*

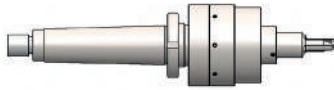
C.M. 4 / Morse taper 4	
	
L. tot.	262
CORPO / Body	STR004.001.01*
GHIERA / Ring	GHKM7
PISTONE / Piston	STR004.003.02*
CODICE ASSIEME / Code	STR004.000.10*

C.M. 5 / Morse taper 5	
	
L. tot.	292
CORPO / Body	STR005.001.01*
GHIERA / Ring	GHKM10
PISTONE / Piston	STR005.003.02*
CODICE ASSIEME / Code	STR005.000.10*

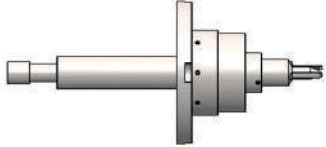
FLANGIATO $\varnothing 109 / \varnothing 109$	
	
L. tot.	242
CORPO / Body	STR109.001.01*
PISTONE / Piston	STR003.003.02*
CODICE ASSIEME / Code	STR109.000.10*

ARTIGLIO / Driving pin	
	
\varnothing	6
L.	54
CODICE / Code	DTSR00.006.01*

* Articoli con scorta minima limitata a magazzino, non garantita disponibilità immediata / Items with limited minimum stock, immediate availability not guaranteed

SERIE STR \varnothing 12 mm

Trascinatore idraulico / pneumatico
 Hydraulic / Pneumatic face driver

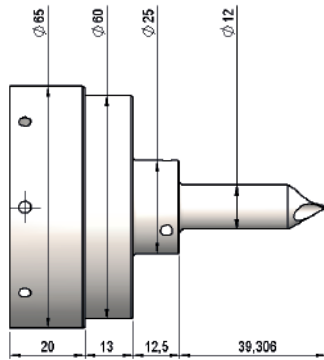

TESTINA / Head	STR003.002.01*
----------------	----------------

	RANELLA / Nut	STR003.004.01*
	PINZA / Clamp	STR003.005.01*
	PISTONE / Piston	Vedi sotto / See below

C.M. 3 / Morse taper 3	
L. tot.	233
CORPO / Body	STR003.001.01*
GHIERA / Ring	GHKM6
PISTONE / Piston	STR003.003.02*
CODICE ASSIEME / Code	STR003.000.12*

C.M. 4 / Morse taper 4	
L. tot.	253
CORPO / Body	STR004.001.01*
GHIERA / Ring	GHKM7
PISTONE / Piston	STR004.003.02*
CODICE ASSIEME / Code	STR004.000.12*

C.M. 5 / Morse taper 5	
L. tot.	283
CORPO / Body	STR005.001.01*
GHIERA / Ring	GHKM10
PISTONE / Piston	STR005.003.02*
CODICE ASSIEME / Code	STR005.000.12*

FLANGIATO \varnothing 109 / \varnothing 109	
L. tot.	233
CORPO / Body	STR003.007.01*
PISTONE / Piston	STR003.003.02*
CODICE ASSIEME / Code	STR109.000.12*

ARTIGLIO STANDARD / Standard driving pin	
\varnothing	4,5
L.	46
CODICE / Code	DTSR00.006.02*

ARTIGLIO SCARICATO / Unloaded driving pin	
\varnothing	4,5
L.	46
CODICE / Code	DTSR00.006.03*

ARTIGLIO ZIGRINATO / Milled driving pin	
\varnothing	4,5
L.	46
CODICE / Code	DTSR00.006.17*

* Articoli con scorta minima limitata a magazzino, non garantita disponibilità immediata / Items with limited minimum stock, immediate availability not guaranteed

SERIE STR $\varnothing 15$ mm

Trascinatore idraulico / pneumatico
 Hydraulic / Pneumatic face driver

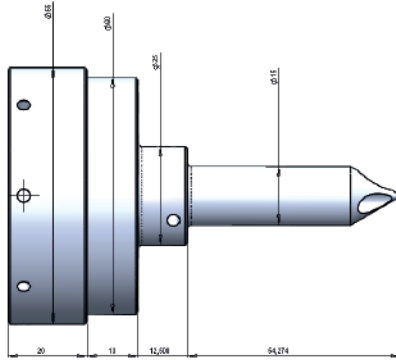

TESTINA / Head	STR003.002.60*
----------------	----------------

	RANELLA / Nut	STR003.004.01*
	PINZA / Clamp	STR003.005.01*
	PISTONE / Piston	Vedi sotto / See below

C.M. 3 / Morse taper 3	
L. tot.	253
CORPO / Body	STR003.001.01*
GHIERA / Ring	GHKM6
PISTONE / Piston	STR003.003.02*
CODICE ASSIEME / Code	STR003.000.15*

C.M. 4 / Morse taper 4	
L. tot.	253
CORPO / Body	STR004.001.01*
GHIERA / Ring	GHKM7
PISTONE / Piston	STR004.003.02*
CODICE ASSIEME / Code	STR004.000.15*

C.M. 5 / Morse taper 5	
L. tot.	253
CORPO / Body	STR005.001.01*
GHIERA / Ring	GHKM10
PISTONE / Piston	STR005.003.02*
CODICE ASSIEME / Code	STR005.000.15*

FLANGIATO $\varnothing 109 / \varnothing 109$	
L. tot.	233
CORPO / Body	STR003.007.01*
PISTONE / Piston	STR003.003.02*
CODICE ASSIEME / Code	STR109.000.15*

ARTIGLIO STANDARD / Standard driving pin	
\varnothing	5
L.	62
CODICE / Code	DTSR00.006.16*

ARTIGLIO RIBASSATO / Low driving pin	
\varnothing	5
L.	62
CODICE / Code	DTSR00.006.13*

ARTIGLIO ZIGRINATO / Milled driving pin	
\varnothing	5
L.	62
CODICE / Code	DTSR00.006.15*

ARTIGLIO SCARICATO / Unloaded driving pin	
\varnothing	5
L.	62
CODICE / Code	DTSR00.006.14*



* Articoli con scorta minima limitata a magazzino, non garantita disponibilità immediata /
 Items with limited minimum stock, immediate availability not guaranteed

SERIE STR \varnothing 20 mm

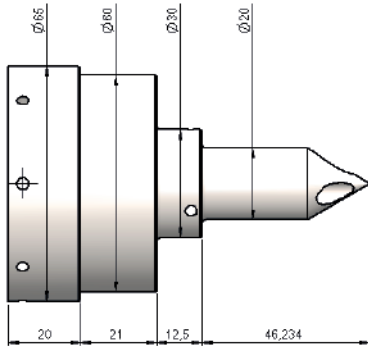
Trascinatore idraulico / pneumatico
 Hydraulic / Pneumatic face driver



TESTINA / Head	STR003.002.02*
----------------	----------------

		
RANELLA / Nut	STR003.004.02*	
PINZA / Clamp	STR003.005.02*	
PISTONE / Piston	Vedi sotto / See below	

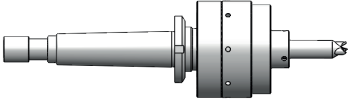
C.M. 3 / Morse taper 3	
	
L. tot.	242
CORPO / Body	STR003.001.01*
GHIERA / Ring	GHKM6
PISTONE / Piston	STR003.003.02*
CODICE ASSIEME / Code	STR003.000.20*

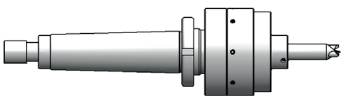
C.M. 4 / Morse taper 4	
	
L. tot.	262
CORPO / Body	STR004.001.01*
GHIERA / Ring	GHKM7
PISTONE / Piston	STR004.003.02*
CODICE ASSIEME / Code	STR004.000.20*

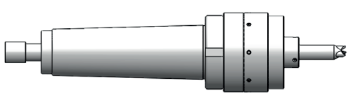
C.M. 5 / Morse taper 5	
	
L. tot.	292
CORPO / Body	STR005.001.01*
GHIERA / Ring	GHKM10
PISTONE / Piston	STR005.003.02*
CODICE ASSIEME / Code	STR005.000.20*

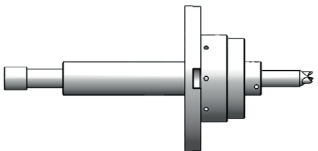
FLANGIATO \varnothing 109 / \varnothing 109	
	
L. tot.	242
CORPO / Body	STR003.007.01*
PISTONE / Piston	STR003.003.02*
CODICE ASSIEME / Code	STR109.000.20*

ARTIGLIO STANDARD / Standard driving pin	
	
\varnothing	6
L.	54
CODICE / Code	DTSR00.006.04*

ARTIGLIO SCARICATO / Unloaded driving pin	
	
\varnothing	6
L.	54
CODICE / Code	DTSR00.006.05*

ARTIGLIO ZIGRINATO / Milled driving pin	
	
\varnothing	6
L.	54
CODICE / Code	DTSR00.006.06*

* Articoli con scorta minima limitata a magazzino, non garantita disponibilità immediata / Items with limited minimum stock, immediate availability not guaranteed

SERIE STR $\varnothing 25$ mm

Trascinatore idraulico / pneumatico
 Hydraulic / Pneumatic face driver

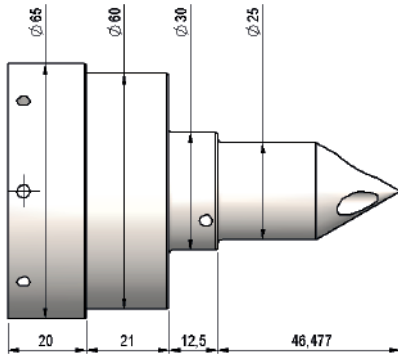

TESTINA / Head	STR003.002.07*
----------------	----------------

	RANELLA / Nut	STR003.004.02*
	PINZA / Clamp	STR003.005.02*
	PISTONE / Piston	Vedi sotto / See below

C.M. 3 / Morse taper 3	
L. tot.	242
CORPO / Body	STR003.001.01*
GHIERA / Ring	GHKM6
PISTONE / Piston	STR003.003.02*
CODICE ASSIEME / Code	STR003.000.25*

C.M. 4 / Morse taper 4	
L. tot.	262
CORPO / Body	STR004.001.01*
GHIERA / Ring	GHKM7
PISTONE / Piston	STR004.003.02*
CODICE ASSIEME / Code	STR004.000.25*

C.M. 5 / Morse taper 5	
L. tot.	292
CORPO / Body	STR005.001.01*
GHIERA / Ring	GHKM10
PISTONE / Piston	STR005.003.02*
CODICE ASSIEME / Code	STR005.000.25*

FLANGIATO $\varnothing 109 / \varnothing 109$	
L. tot.	242
CORPO / Body	STR003.007.01*
PISTONE / Piston	STR003.003.02*
CODICE ASSIEME / Code	STR109.000.25*

ARTIGLIO STANDARD / Standard driving pin	
\varnothing	6
L.	54
CODICE / Code	DTSR00.006.04*
\varnothing	6
L.	50
CODICE / Code	DTSR00.006.10*

ARTIGLIO SCARICATO / Unloaded driving pin	
\varnothing	6
L.	54
CODICE / Code	DTSR00.006.05*
\varnothing	6
L.	50
CODICE / Code	DTSR00.006.11*

ARTIGLIO ZIGRINATO / Milled driving pin	
\varnothing	6
L.	54
CODICE / Code	DTSR00.006.06*
\varnothing	6
L.	50
CODICE / Code	DTSR00.006.12*



* Articoli con scorta minima limitata a magazzino, non garantita disponibilità immediata / Items with limited minimum stock, immediate availability not guaranteed

SERIE STR $\varnothing 30$ mm

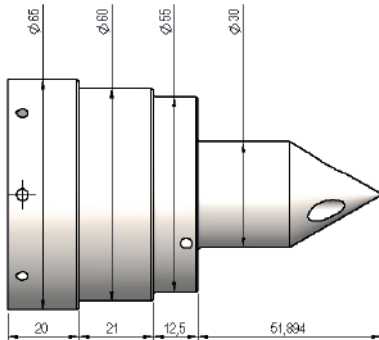
Trascinatore idraulico / pneumatico
 Hydraulic / Pneumatic face driver



TESTINA / Head	STR003.002.03*
----------------	----------------

		
RANELLA / Nut	STR003.004.03*	
PINZA / Clamp	STR003.005.03*	
PISTONE / Piston	Vedi sotto / See below	

C.M. 3 / Morse taper 3	
	
L. tot.	248
CORPO / Body	STR003.001.01*
GHIERA / Ring	GHKM6
PISTONE / Piston	STR003.003.02*
CODICE ASSIEME / Code	STR003.000.30*

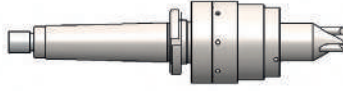
C.M. 4 / Morse taper 4	
	
L. tot.	268
CORPO / Body	STR004.001.01*
GHIERA / Ring	GHKM7
PISTONE / Piston	STR004.003.02*
CODICE ASSIEME / Code	STR004.000.30*

C.M. 5 / Morse taper 5	
	
L. tot.	298
CORPO / Body	STR005.001.01*
GHIERA / Ring	GHKM10
PISTONE / Piston	STR005.003.02*
CODICE ASSIEME / Code	STR005.000.30*

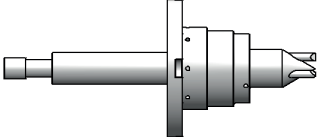
FLANGIATO $\varnothing 109$ / $\varnothing 109$	
	
L. tot.	248
CORPO / Body	STR003.007.01*
PISTONE / Piston	STR003.003.02*
CODICE ASSIEME / Code	STR109.000.30*

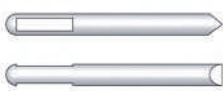
ARTIGLIO STANDARD / Standard driving pin	
	
\varnothing	6
L.	54
CODICE / Code	DTSR00.006.04*
\varnothing	6
L.	60
CODICE / Code	DTSR00.006.07*

ARTIGLIO SCARICATO / Unloaded driving pin	
	
\varnothing	6
L.	54
CODICE / Code	DTSR00.006.05*
\varnothing	6
L.	60
CODICE / Code	DTSR00.006.08*

ARTIGLIO ZIGRINATO / Milled driving pin	
	
\varnothing	6
L.	54
CODICE / Code	DTSR00.006.06*
\varnothing	6
L.	60
CODICE / Code	DTSR00.006.09*



* Articoli con scorta minima limitata a magazzino, non garantita disponibilità immediata / Items with limited minimum stock, immediate availability not guaranteed

SERIE STR $\varnothing 35$ mm

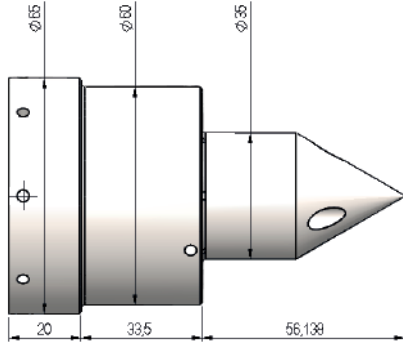
Trascinatore idraulico / pneumatico
 Hydraulic / Pneumatic face driver



TESTINA / Head	STR003.002.05*
----------------	----------------

		
RANELLA / Nut	STR003.004.05*	
PINZA / Clamp	STR003.005.06*	
PISTONE / Piston	Vedi sotto / See below	

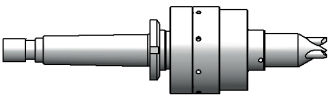
C.M. 3 / Morse taper 3	
	
L. tot.	252
CORPO / Body	STR003.001.01*
GHIERA / Ring	GHKM6
PISTONE / Piston	STR003.003.02*
CODICE ASSIEME / Code	STR003.000.35*

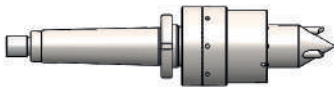
C.M. 4 / Morse taper 4	
	
L. tot.	272
CORPO / Body	STR004.001.01*
GHIERA / Ring	GHKM7
PISTONE / Piston	STR004.003.02*
CODICE ASSIEME / Code	STR004.000.35*

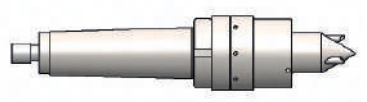
C.M. 5 / Morse taper 5	
	
L. tot.	302
CORPO / Body	STR005.001.01*
GHIERA / Ring	GHKM10
PISTONE / Piston	STR005.003.02*
CODICE ASSIEME / Code	STR005.000.35*

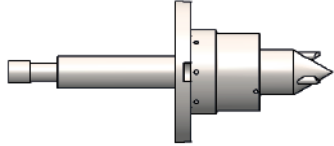
FLANGIATO $\varnothing 109 / \varnothing 109$	
	
L. tot.	252
CORPO / Body	STR003.007.01*
PISTONE / Piston	STR003.003.02*
CODICE ASSIEME / Code	STR109.000.35*

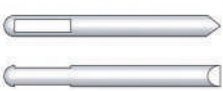
ARTIGLIO STANDARD / Standard driving pin	
	
\varnothing	6
L.	50
CODICE / Code	DTSR00.006.10*
\varnothing	6
L.	54
CODICE / Code	DTSR00.006.04*
\varnothing	6
L.	60
CODICE / Code	DTSR00.006.07*

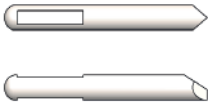
ARTIGLIO SCARICATO / Unloaded driving pin	
	
\varnothing	6
L.	50
CODICE / Code	DTSR00.006.11*
\varnothing	6
L.	54
CODICE / Code	DTSR00.006.05*
\varnothing	6
L.	60
CODICE / Code	DTSR00.006.08*

ARTIGLIO ZIGRINATO / Milled driving pin	
	
\varnothing	6
L.	50
CODICE / Code	DTSR00.006.12*
\varnothing	6
L.	54
CODICE / Code	DTSR00.006.06*
\varnothing	6
L.	60
CODICE / Code	DTSR00.006.09*



* Articoli con scorta minima limitata a magazzino, non garantita disponibilità immediata / Items with limited minimum stock, immediate availability not guaranteed

SERIE STR \varnothing 40 mm

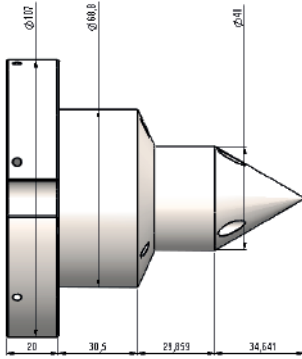
Trascinatore idraulico / pneumatico
 Hydraulic / Pneumatic face driver



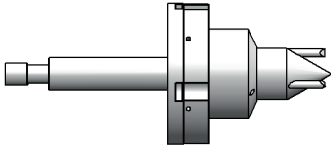

TESTINA / Head	STR003.002.08*
----------------	----------------

		
RANELLA / Nut	STR003.004.07*	
PINZA / Clamp	STR003.005.08*	
PISTONE / Piston	Vedi sotto / See below	

FLANGIATO \varnothing 109 / \varnothing 109	
	
L. tot.	253
CORPO / Body	STR003.007.01*
PISTONE / Piston	STR003.003.02*
CODICE ASSIEME / Code	STR109.000.40*

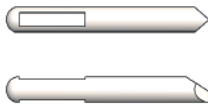
ARTIGLIO STANDARD / Standard driving pin	
	
\varnothing	6
L.	50
CODICE / Code	DTSR00.006.10*
\varnothing	6
L.	54
CODICE / Code	DTSR00.006.04*
\varnothing	6
L.	60
CODICE / Code	DTSR00.006.07*

ARTIGLIO SCARICATO / Unloaded driving pin	
	
\varnothing	6
L.	50
CODICE / Code	DTSR00.006.11*
\varnothing	6
L.	54
CODICE / Code	DTSR00.006.05*
\varnothing	6
L.	60
CODICE / Code	DTSR00.006.08*

ARTIGLIO ZIGRINATO / Milled driving pin	
	
\varnothing	6
L.	50
CODICE / Code	DTSR00.006.12*
\varnothing	6
L.	54
CODICE / Code	DTSR00.006.06
\varnothing	6
L.	60
CODICE / Code	DTSR00.006.09*

* Articoli con scorta minima limitata a magazzino, non garantita disponibilità immediata / Items with limited minimum stock, immediate availability not guaranteed

SERIE STR \varnothing 50 mm

Trascinatore idraulico / pneumatico
 Hydraulic / Pneumatic face driver

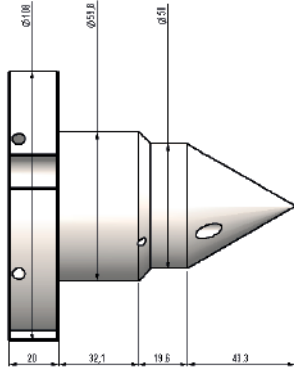

TESTINA / Head	STR003.002.05*
----------------	----------------

	RANELLA / Nut	STR003.004.09*
	PINZA / Clamp	STR003.005.10*
	PISTONE / Piston	Vedi sotto / See below

FLANGIATO \varnothing 109 / \varnothing 109	
L. tot.	253
CORPO / Body	STR003.007.01*
PISTONE / Piston	STR003.003.02*
CODICE ASSIEME / Code	STR109.000.50*

ARTIGLIO STANDARD / Standard driving pin	
\varnothing	6
L.	60
CODICE / Code	DTSR00.006.07*

ARTIGLIO SCARICATO / Unloaded driving pin	
\varnothing	6
L.	60
CODICE / Code	DTSR00.006.08*

ARTIGLIO ZIGGINATO / Milled driving pin	
\varnothing	6
L.	60
CODICE / Code	DTSR00.006.09*

* Articoli con scorta minima limitata a magazzino, non garantita disponibilità immediata / Items with limited minimum stock, immediate availability not guaranteed

