



04 Mandrini autocentranti

SERIE AUT-GS-3+3

3

*MANDRINI AUTOCENTRANTI GUIDA SEMPLICE 3+3 / SELF-CENTERING CHUCKS - 3 JAWS SINGLE SLOT
SPANNFUTTER MIT 3 KLEMMEN - EINFÜHRUNG / PLATEAU A CENTRAGE AUTOMATIQUE GUIDE SIMPLE 3+3*

SERIE AUT-A-GS-3+3

4

*MANDRINI AUTOCENTRANTI ACCIAIO GUIDA SEMPLICE 3+3 / SELF-CENTERING CHUCKS - 3 JAWS SINGLE SLOT
SPANNFUTTER MIT 3 KLEMMEN - EINFÜHRUNG / PLATEAU A CENTRAGE AUTOMATIQUE GUIDE SIMPLE 3+3*

SERIE AUT-GD-3+3

5

*MANDRINI AUTOCENTRANTI GUIDA DOPPIA 3+3 / SELF-CENTERING CHUCKS - 3 JAWS DOUBLE SLOT
SPANNFUTTER MIT 3 KLEMMEN - DOPPELFÜHRUNG / PLATEAU A CENTRAGE AUTOMATIQUE GUIDE DOUBLE 3+3*

SERIE AUT-GS-4+4

6

*MANDRINI AUTOCENTRANTI GUIDA SEMPLICE 4+4 / SELF-CENTERING CHUCKS - 3 JAWS SINGLE SLOT
SPANNFUTTER MIT 3 KLEMMEN - EINFÜHRUNG / PLATEAU A CENTRAGE AUTOMATIQUE GUIDE SIMPLE 4+4*

SERIE AUT-A-GS-4+4

7

*MANDRINI AUTOCENTRANTI ACCIAIO GUIDA SEMPLICE 4+4 / SELF-CENTERING CHUCKS - 3 JAWS SINGLE SLOT
SPANNFUTTER MIT 3 KLEMMEN - EINFÜHRUNG / PLATEAU A CENTRAGE AUTOMATIQUE GUIDE SIMPLE 4+4*

SERIE AUT-GD-4+4

8

*MANDRINI AUTOCENTRANTI GUIDA DOPPIA 4+4 / SELF-CENTERING CHUCKS - 4 JAWS DOUBLE SLOT
SPANNFUTTER MIT 4 KLEMMEN - DOPPELFÜHRUNG / PLATEAU A CENTRAGE AUTOMATIQUE GUIDE DOUBLE 4+4*

SERIE AMT-FLC

9

*MORSETTI TENERI E FLANGE IN GHISA PER AUTOCENTRANTI / CAST IRON FLANGES FOR SELF-CENTERING CHUCKS
GUSSFLANSCH FÜR SPANNFUTTER / BRIDE EN FONTE POUR PLATEAU A CENTRAGE*

SERIE FLD-FLA

10

*FLANGE IN GHISA PER AUTOCENTRANTI / CAST IRON FLANGES FOR SELF-CENTERING CHUCKS
GUSSFLANSCH FÜR SPANNFUTTER / BRIDE EN FONTE POUR PLATEAU A CENTRAGE*

Serie AUT-GS-3+3

MANDRINI AUTOCENTRANTI GHISA GUIDA SEMPLICE 3+3
SELF-CENTERING CHUCKS - 3 JAWS SINGLE SLOT
SPANNFUTTER MIT 3 KLEMMEN - EINFÜHRUNG
PLATEAU À CENTRAGE AUTOMATIQUE GUIDE SIMPLE 3+3



OPTIONAL a pag. 04 / 9

FORNIBILI ANCHE CON FORI DI FISSAGGIO ANTERIORI. RICHIEDERE PREZZI AL NS. UFFICIO VENDITA
FURNISHABLE WITH FRONT FIXING HOLES - CHECK PICES WITH OUR SALES DEPT
SPANNFUTTER MIT VORAUFSPANNBOHREN AUSGELIEFERN. PREISE AUF ANFRAGE
ON PEUT FOURNIR AUSSI AVEC TROUS DE FIXAGE ANTERIEURS. PRIX À LA DEMANDE

Ø	A	B	C	D	E	F	G	PESO Weight Gewicht Poids Kg	SERIE/SERIES	CODICE/CODE
80	80	44	56 H7	16	67	N°3XM6	57	1,6	AUT080-GS-3+3	AUT080.000.3S
100	100	50	70 H7	20	83	N°3XM8	67	2,8	AUT100-GS-3+3	AUT100.000.3S
125	125	56	95 H7	32	108	N°3XM8	76	5	AUT125-GS-3+3	AUT125.000.3S
160	160	64,5	125 H7	42	140	N°6XM10	96,5	10	AUT160-GS-3+3	AUT160.000.3S
200	200	75	160 H7	55	176	N°6XM10	104	17,5	AUT200-GS-3+3	AUT200.000.3S
250	250	85	200 H7	76	224	N°6XM12	119	29	AUT250-GS-3+3	AUT250.000.3S
315	315	94	260 H7	103	286	N°6XM16	137	50	AUT315-GS-3+3	AUT315.000.3S
400	400	105	330 H7	136	362	N°6XM16	160	88	AUT400-GS-3+3	AUT400.000.3S
500	500	120	420 H7	190	458	N°6XM16	180	145	AUT500-GS-3+3	AUT500.000.3S
630	630	135	545 H7	252	586	N°6XM16	205	250	AUT630-GS-3+3	AUT630.000.3S
800	800	159	450 H7	320	368	N°6XM24	229	402	AUT800-GS-3+3	AUT800.000.3S

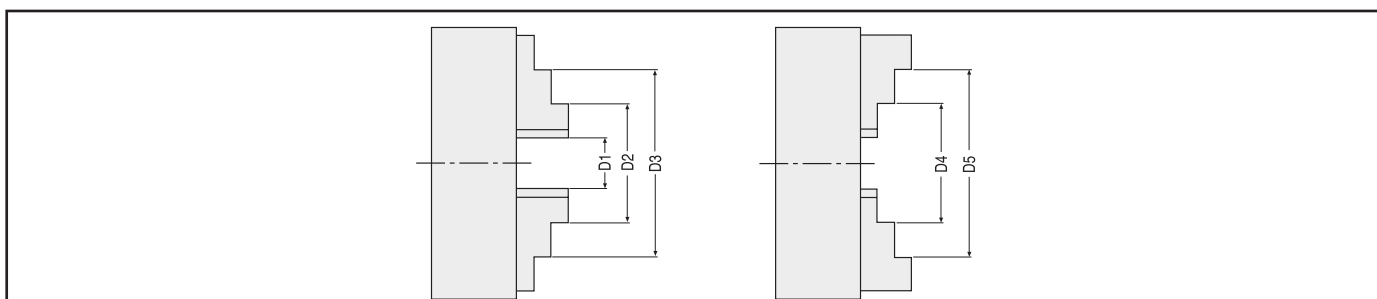

Ø	N° GIRI MAX. R.P.M. MAX U/MIN T/MIN	D1		D2		D3		D4		D5	
		MIN.	MAX.	MIN.	MAX.	MIN.	MAX.	MIN.	MAX.	MIN.	MAX.
80	4000	2	27	22	48	45	69	25	50	48	71
100	3500	3	33	25	58	56	87	32	62	62	83
125	3200	3	50	34	74	72	115	39	83	80	125
160	3000	3	64	42	100	94	154	50	107	98	160
200	2500	4	90	52	135	120	202	80	145	130	200
250	2000	5	118	62	174	145	258	77	188	160	250
315	1500	10	131	78	200	172	299	90	215	190	315
400	1000	10	180	85	252	210	360	103	272	230	400
500	700	20	235	120	335	245	475	140	357	276	500
630	500	30	335	160	487	325	630	180	487	345	630
800	300	150	482	282	614	448	780	302	634	468	800

Serie AUT-A-GS-3+3

MANDRINI AUTOCENTRANTI ACCIAIO GUIDA SEMPLICE 3+3

SELF-CENTERING CHUCKS - 3 JAWS SINGLE SLOT

SPANNFUTTER MIT 3 KLEMMEN - EINFÜHRUNG

PLATEAU À CENTRAGE AUTOMATIQUE GUIDE SIMPLE 3+3

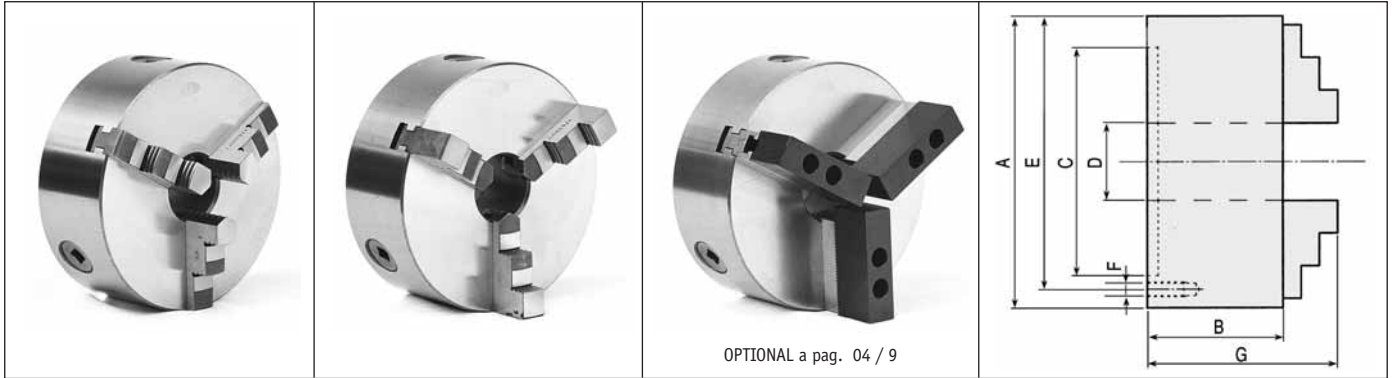

OPTIONAL a pag. 04 / 9

FORNIBILI ANCHE CON FORI DI FISSAGGIO ANTERIORI. RICHIEDERE PREZZI AL NS. UFFICIO VENDITA
FURNISHABLE WITH FRONT FIXING HOLES - CHECK PICES WITH OUR SALES DEPT
SPANNFUTTER MIT VORAUFSPANNBOHREN AUSGELIEFERN. PREISE AUF ANFRAGE
ON PEUT FOURNIR AUSSI AVEC TROUS DE FIXAGE ANTERIEURS. PRIX À LA DEMANDE

Ø	A	B	C	D	E	F	G	PESO Weight Gewicht Poids Kg	SERIE/SERIES	CODICE/CODE
80	80	44	56 H7	16	67	N°3XM6	57	1,6	AUT-A-080-GS-3+3	AUT080.001.3S
100	100	50	70 H7	20	83	N°3XM8	67	2,8	AUT-A-100-GS-3+3	AUT100.001.3S
125	125	56	95 H7	32	108	N°3XM8	76	4,8	AUT-A-125-GS-3+3	AUT125.001.3S
160	160	64,5	125 H7	42	140	N°6XM10	96,5	8,5	AUT-A-160-GS-3+3	AUT160.001.3S
200	200	75	160 H7	55	176	N°6XM10	104	16	AUT-A-200-GS-3+3	AUT200.001.3S
250	250	85	200 H7	76	224	N°6XM12	119	26	AUT-A-250-GS-3+3	AUT250.001.3S
315	315	94	260 H7	103	286	N°6XM16	137	43	AUT-A-315-GS-3+3	AUT315.001.3S
400	400	105	330 H7	136	362	N°6XM16	160	80	AUT-A-400-GS-3+3	AUT400.001.3S
500	500	120	420 H7	190	458	N°6XM16	180	125	AUT-A-500-GS-3+3	AUT500.001.3S
630	630	135	545 H7	252	586	N°6XM16	205	220	AUT-A-630-GS-3+3	AUT630.001.3S

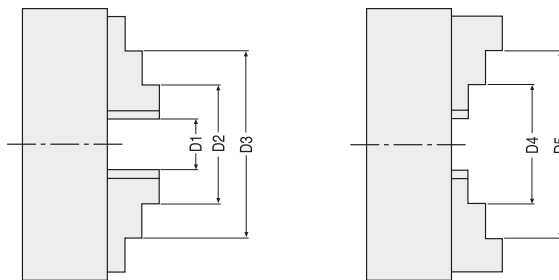

Ø	N° GIRI MAX. R.P.M. MAX U/MIN T/MIN	D1		D2		D3		D4		D5	
		MIN.	MAX.	MIN.	MAX.	MIN.	MAX.	MIN.	MAX.	MIN.	MAX.
80	6000	2	27	22	48	45	69	25	50	48	71
100	5200	3	33	25	58	56	87	32	62	62	63
125	4800	3	50	34	74	72	115	39	83	80	125
160	4500	3	64	42	100	94	154	50	107	98	160
200	4000	4	90	52	135	120	202	60	145	130	200
250	3500	5	118	62	174	145	256	77	188	160	250
315	2800	10	135	78	200	172	299	90	225	190	315
400	2000	10	180	85	252	210	360	103	272	230	400
500	1200	20	235	120	335	245	475	140	357	276	500
630	1000	30	335	160	487	325	630	180	487	345	630

Serie AUT-GD-3+3

MANDRINI AUTOCENTRANTI GHISA GUIDA DOPPIA 3+3
SELF-CENTERING CHUCKS - 3 JAWS DOUBLE SLOT
SPANNFUTTER MIT 3 KLEMMEN - DOPPELFÜHRUNG
PLATEAU À CENTRAGE AUTOMATIQUE GUIDE DOUBLE 3+3

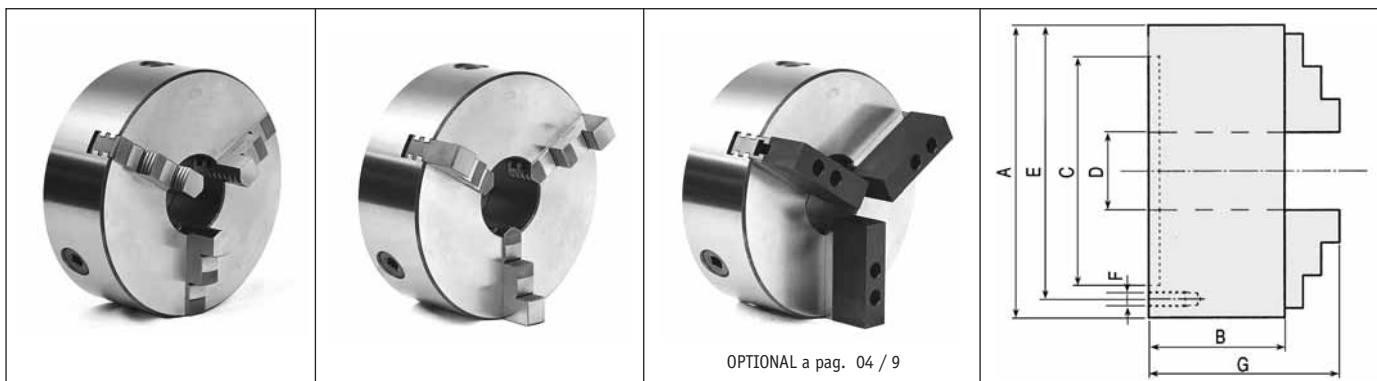

OPTIONAL a pag. 04 / 9

FORNIBILI ANCHE CON FORI DI FISSAGGIO ANTERIORI. RICHIEDERE PREZZI AL NS. UFFICIO VENDITA
FURNISHABLE WITH FRONT FIXING HOLES - CHECK PICES WITH OUR SALES DEPT
SPANNFUTTER MIT VORAUFSPANNBOHREN AUSGELIEFERN. PREISE AUF ANFRAGE
ON PEUT FOURNIR AUSSI AVEC TROUS DE FIXAGE ANTERIEURS. PRIX À LA DEMANDE

Ø	A	B	C	D	E	F	G	PESO Weight Gewicht Poids Kg	SERIE/SERIES	CODICE/CODE
160	160	64,5	125 H7	42	140	№6M10	96,5	9,7	AUT160-GD-3+3	AUT160.000.3D
200	200	75	160 H7	55	176	№6M10	104	17,2	AUT200-GD-3+3	AUT200.000.3D
250	250	85	200 H7	76	224	№6M12	119	29,3	AUT250-GD-3+3	AUT250.000.3D
270	270	96	228 H7	105	246	№6M12	130	35	AUT270-GD-3+3	AUT270.000.3D
315	315	94	260 H7	103	286	№6M16	137	50	AUT315-GD-3+3	AUT315.000.3D
400	400	105	330 H7	136	362	№6M16	160	91,6	AUT400-GD-3+3	AUT400.000.3D
500	500	120	420 H7	190	458	№6M16	180	128	AUT500-GD-3+3	AUT500.000.3D
630	630	135	545 H7	252	586	№6M16	205	220	AUT630-GD-3+3	AUT630.000.3D

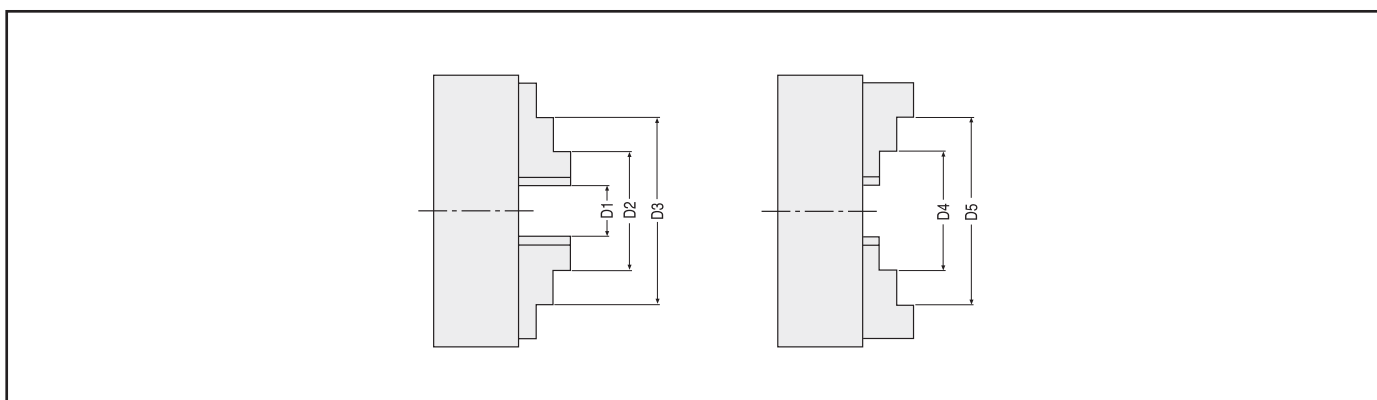

Ø	N° GIRI MAX. R.P.M. MAX U/MIN T/MIN	D1		D2		D3		D4		D5	
		MIN.	MAX.	MIN.	MAX.	MIN.	MAX.	MIN.	MAX.	MIN.	MAX.
160	3000	3	64	42	100	94	154	50	107	98	160
200	2500	4	90	52	135	120	202	60	145	130	200
250	2000	5	118	62	174	145	256	77	188	160	250
270	2000	5	125	67	185	155	270	82	200	170	270
315	1500	5	135	78	200	172	299	90	225	190	315
400	1000	10	180	86	252	210	350	103	272	230	400
500	1000	20	235	120	335	245	476	140	357	190	500
630	500	30	335	160	487	325	630	180	487	345	630

Serie AUT-GS-4+4

MANDRINI AUTOCENTRANTI GHISA GUIDA SEMPLICE 4+4
SELF-CENTERING CHUCKS - 3 JAWS SINGLE SLOT
SPANNFUTTER MIT 3 KLEMMEN - EINFÜHRUNG
PLATEAU À CENTRAGE AUTOMATIQUE GUIDE SIMPLE 4+4

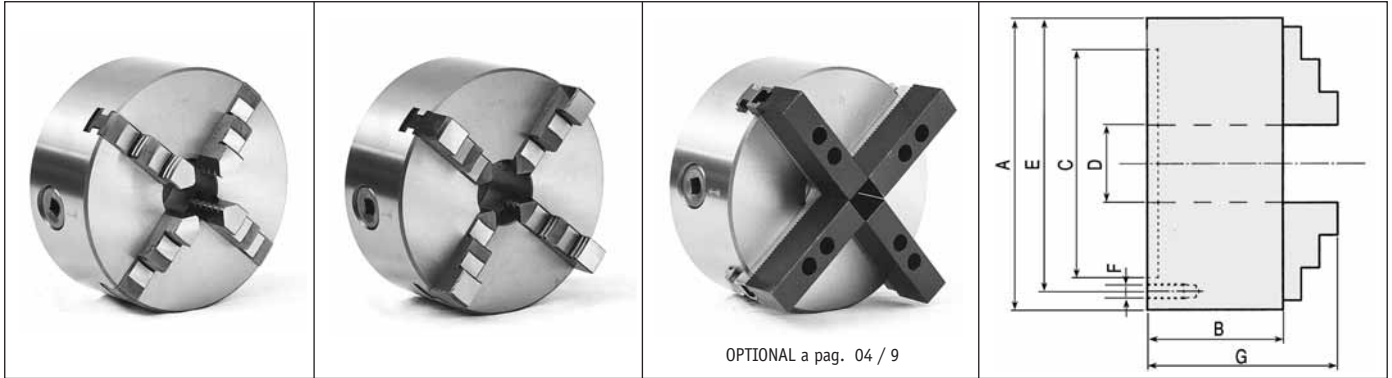

OPTIONAL a pag. 04 / 9

FORNIBILI ANCHE CON FORI DI FISSAGGIO ANTERIORI. RICHIEDERE PREZZI AL NS. UFFICIO VENDITA
FURNISHABLE WITH FRONT FIXING HOLES - CHECK PICES WITH OUR SALES DEPT
SPANNFUTTER MIT VORAUFSPANNBOHREN AUSGELIEFERN. PREISE AUF ANFRAGE
ON PEUT FOURNIR AUSSI AVEC TROUS DE FIXAGE ANTERIEURS. PRIX À LA DEMANDE

Ø	A	B	C	D	E	F	G	PESO Weight Gewicht Poids Kg	SERIE/SERIES	CODICE/CODE
80	80	44	56 H7	16	67	№3XM6	57	1,6	AUT080-GS-4+4	AUT080.000.4S
100	100	50	70 H7	20	83	№3XM8	67	2,8	AUT100-GS-4+4	AUT100.000.4S
125	125	56	95 H7	32	108	№3XM8	76	5	AUT125-GS-4+4	AUT125.000.4S
160	160	64,5	125 H7	42	140	№6XM10	96,5	10	AUT160-GS-4+4	AUT160.000.4S
200	200	75	160 H7	55	176	№6XM10	104	17,5	AUT200-GS-4+4	AUT200.000.4S
250	250	85	200 H7	76	224	№6XM12	119	29	AUT250-GS-4+4	AUT250.000.4S
315	315	94	260 H7	103	286	№6XM16	137	50	AUT315-GS-4+4	AUT315.000.4S
400	400	105	330 H7	136	362	№6XM16	160	88	AUT400-GS-4+4	AUT400.000.4S
500	500	120	420 H7	190	458	№6XM16	180	145	AUT500-GS-4+4	AUT500.000.4S

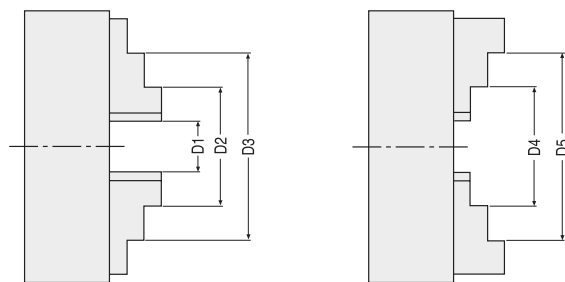

Ø	N° GIRI MAX. R.P.M. MAX U/MIN T/MIN	D1		D2		D3		D4		D5	
		MIN.	MAX.	MIN.	MAX.	MIN.	MAX.	MIN.	MAX.	MIN.	MAX.
80	4000	2	27	22	48	45	69	25	50	48	71
100	3500	3	33	25	58	56	87	32	62	62	63
125	3200	3	50	34	74	72	115	39	83	80	125
160	3000	3	64	42	100	94	154	50	107	98	160
200	2500	4	90	52	135	120	202	80	145	130	200
250	2000	5	118	62	174	145	258	77	188	160	250
315	1500	10	131	78	200	172	299	90	215	190	315
400	1000	10	180	85	252	210	360	103	272	230	400
500	700	20	235	120	335	245	475	140	357	276	500

Serie AUT-A-GS-4+4

MANDRINI AUTOCENTRANTI ACCIAIO GUIDA SEMPLICE 4+4

SELF-CENTERING CHUCKS - 3 JAWS SINGLE SLOT

SPANNFUTTER MIT 3 KLEMMEN - EINFÜHRUNG

PLATEAU À CENTRAGE AUTOMATIQUE GUIDE SIMPLE 4+4

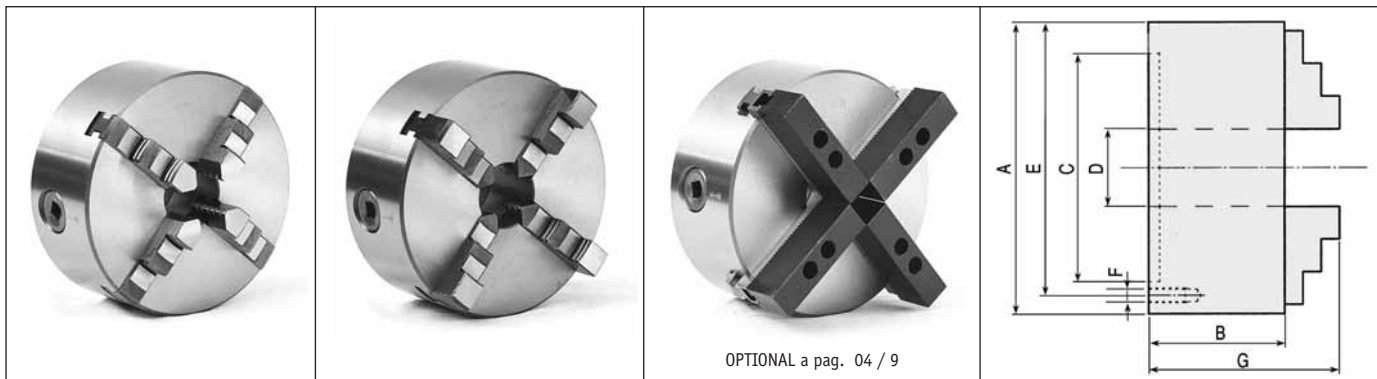

OPTIONAL a pag. 04 / 9

FORNIBILI ANCHE CON FORI DI FISSAGGIO ANTERIORI. RICHIEDERE PREZZI AL NS. UFFICIO VENDITA

FURNISHABLE WITH FRONT FIXING HOLES - CHECK PICES WITH OUR SALES DEPT
SPANNFUTTER MIT VORAUFSPANNBOHREN AUSGELIEFERN. PREISE AUF ANFRAGE
ON PEUT FOURNIR AUSSI AVEC TROUS DE FIXAGE ANTERIEURS. PRIX À LA DEMANDE

Ø	A	B	C	D	E	F	G	PESO Weight Gewicht Poids Kg	SERIE/SERIES	CODICE/CODE
125	125	56	95 H7	32	108	N°3xM8	76	5	AUT-A-125-GS-4+4	AUT125.001.4S
160	160	64,5	125 H7	42	140	N°6XM10	96,5	10	AUT-A-160-GS-4+4	AUT160.001.4S
200	200	75	160 H7	55	176	N°6XM10	104	17,5	AUT-A-200-GS-4+4	AUT200.001.4S
250	250	85	200 H7	76	224	N°6XM12	119	29	AUT-A-250-GS-4+4	AUT250.001.4S
315	315	94	260 H7	103	286	N°6XM16	137	50	AUT-A-315-GS-4+4	AUT315.001.4S
400	400	105	330 H7	136	362	N°6XM16	160	85	AUT-A-400-GS-4+4	AUT400.001.4S

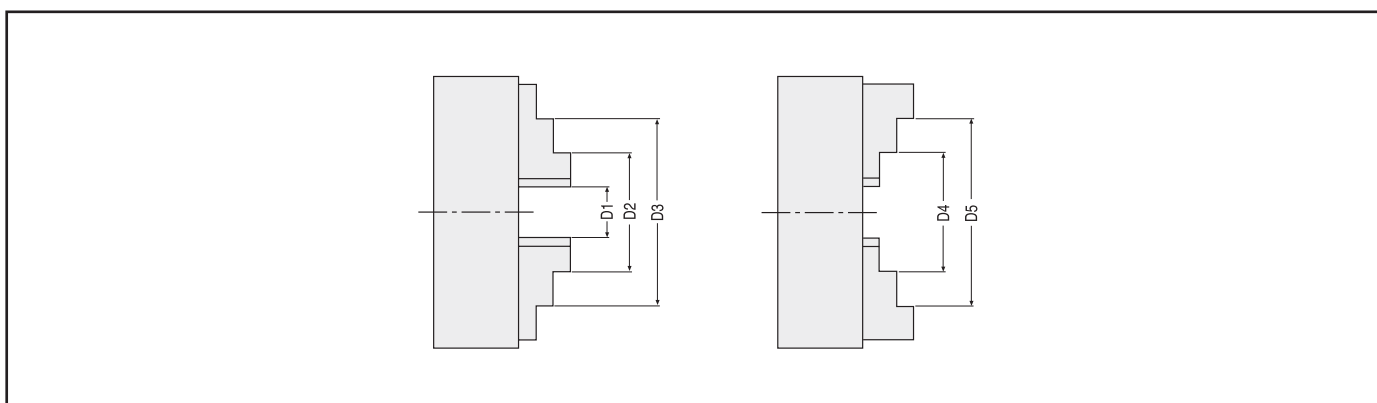

Ø	N° GIRI MAX. R.P.M. MAX U/MIN T/MIN	D1		D2		D3		D4		D5	
		MIN.	MAX.	MIN.	MAX.	MIN.	MAX.	MIN.	MAX.	MIN.	MAX.
125	4800	3	50	34	74	72	115	39	83	80	125
160	4500	3	64	42	100	94	154	50	107	98	160
200	4000	4	90	52	135	120	202	60	145	130	200
250	3500	5	118	62	174	145	256	77	188	160	250
315	2800	5	125	67	185	155	270	82	200	170	270
400	2000	5	135	78	200	172	299	90	225	190	315

Serie AUT-GD-4+4

MANDRINI AUTOCENTRANTI GHISA GUIDA DOPPIA 4+4
SELF-CENTERING CHUCKS - 4 JAWS DOUBLE SLOT
SPANNFUTTER MIT 4 KLEMMEN - DOPPELFÜHRUNG
PLATEAU À CENTRAGE AUTOMATIQUE GUIDE DOUBLE 4+4

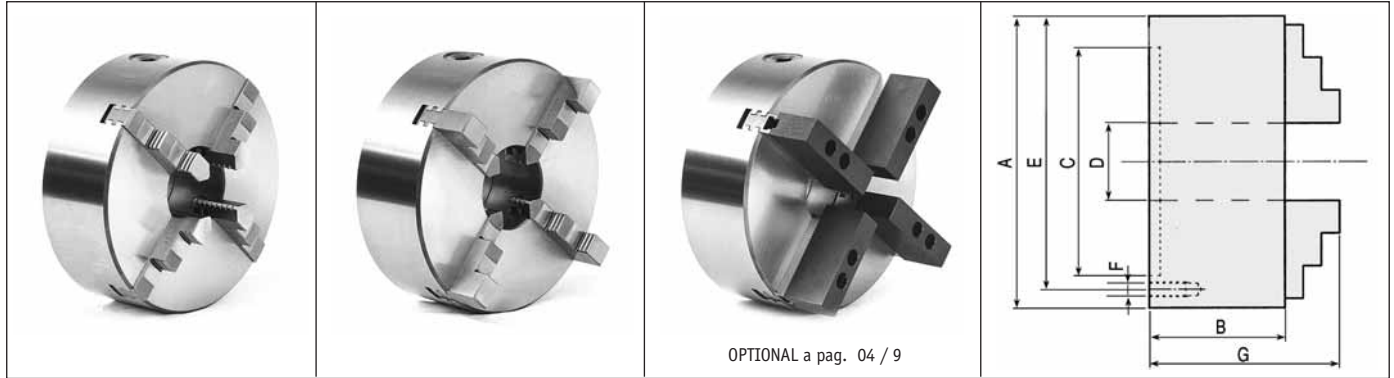

OPTIONAL a pag. 04 / 9

FORNIBILI ANCHE CON FORI DI FISSAGGIO ANTERIORI. RICHIEDERE PREZZI AL NS. UFFICIO VENDITA
FURNISHABLE WITH FRONT FIXING HOLES - CHECK PICES WITH OUR SALES DEPT
SPANNFUTTER MIT VORAUFSPANNBOHREN AUSGELIEFERN. PREISE AUF ANFRAGE
ON PEUT FOURNIR AUSSI AVEC TROUS DE FIXAGE ANTERIEURS. PRIX À LA DEMANDE

Ø	A	B	C	D	E	F	G	PESO Weight Gewicht Poids Kg	SERIE/SERIES	CODICE/CODE
160	160	64,5	125 H7	42	140	№6xM10	96,5	11	AUT160-GD-4+4	AUT160.000.4D
200	200	75	160 H7	55	176	№6xM10	104	19	AUT200-GD-4+4	AUT200.000.4D
250	250	85	200 H7	76	224	№6xM12	119	33	AUT250-GD-4+4	AUT250.000.4D
315	315	94	260 H7	103	286	№6xM16	137	60	AUT315-GD-4+4	AUT315.000.4D
400	400	105	330 H7	136	362	№6xM16	160	97	AUT400-GD-4+4	AUT400.000.4D

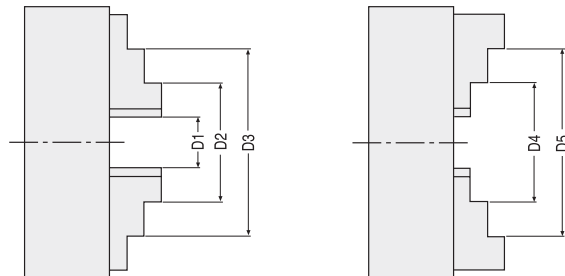

Ø	N° GIRI MAX. R.P.M. MAX U/MIN T/MIN	D1		D2		D3		D4		D5	
		MIN.	MAX.	MIN.	MAX.	MIN.	MAX.	MIN.	MAX.	MIN.	MAX.
160	3000	3	64	42	100	94	154	50	107	98	160
200	2500	4	90	52	135	120	202	60	145	130	200
250	2000	5	118	62	174	145	256	77	188	160	250
315	1500	5	135	78	200	172	299	90	225	190	315
400	1000	10	180	86	252	210	350	103	272	230	400

Serie AMT-FLC

MORSETTI TENERI E FLANGE IN GHISA PER AUTOCENTRANTI
CAST IRON FLANGES FOR SELF-CENTERING CHUCKS
GUSSFLANSCH FÜR SPANNFUTTER
BRIDE EN FONTE POUR PATEAU À CENTRAGE

	DESCRIZIONE DESCRIPTION	SERIE/SERIES	CODICE/Code
	MORSETTO TENERO SINGOLO PER SERIE: AUT. GHISA GS SOFT CLAMP SINGULAR PER SERIES: SELF-CENTERING SINGLEGUIDE CAST IRON WEICHE KLEMMEN EINZEL FÜR SERIEN: AUTOZENTRISCH GUSS MIT EINFACHER FÜHRUNG BORNE TENDRE SINGULE POUR GENRE: AUT. ACIER GS	AMT080-GS	AUT080.100.1S
		AMT100-GS	AUT100.100.1S
		AMT125-GS	AUT125.100.1S
		AMT160-GS	AUT160.100.1S
		AMT200-GS	AUT200.100.1S
		AMT250-GS	AUT250.100.1S
		AMT315-GS	AUT315.100.1S
		AMT400-GS	AUT400.100.1S
		AMT500-GS	AUT500.100.1S
		AMT630-GS	AUT630.100.1S
AMT800-GS	AUT800.100.1S		
	MORSETTO TENERO SINGOLO PER SERIE: AUT. ACCIAIO GS SOFT CLAMP SINGULAR PER SERIES: SELF-CENTERING SINGLEGUIDE CAST STEEL WEICHE KLEMMEN EINZEL FÜR SERIEN: AUTOZENTRISCH GUSS MIT EINFACHER FÜHRUNG BORNE TENDRE SINGULE POUR GENRE: AUT. ACIER GS	AMT-A-080-GS	AUT080.200.1S
		AMT-A-100-GS	AUT100.200.1S
		AMT-A-125-GS	AUT125.200.1S
		AMT-A-160-GS	AUT160.200.1S
		AMT-A-200-GS	AUT200.200.1S
		AMT-A-250-GS	AUT250.200.1S
		AMT-A-315-GS	AUT315.200.1S
		AMT-A-400-GS	AUT400.200.1S
		AMT-A-500-GS	AUT500.200.1S
		AMT-A-630-GS	AUT630.200.1S
	MORSETTO TENERO SINGOLO PER SERIE: AUT. GHISA GD SOFT CLAMP SINGULAR PER SERIES: SELF-CENTERING DOUBLEGUIDE CAST IRON WEICHE KLEMMEN EINZEL FÜR SERIEN: AUTOZENTRISCH GUSS MIT DOPPELTER FÜHRUNG BORNE TENDRE SINGULE POUR GENRE: AUT. FONTE GD	AMT160-GD	AUT160.100.1D
		AMT200-GD	AUT200.100.1D
		AMT250-GD	AUT250.100.1D
		AMT270-GD	AUT270.100.1D
		AMT315-GD	AUT315.100.1D
		AMT400-GD	AUT400.100.1D
		AMT500-GD	AUT500.100.1D
		AMT630-GD	AUT630.100.1D

NB: I MORSETTI TENERI NON POSSONO ESSERE ORDINATI SINGOLARMENTE MA IN SERIE DI TRE O QUATTRO PEZZI, A SECONDO DEL TIPO DI MANDRINO
PLEASE: SOFT CLAMPS CAN'T BE ORDERED SEPARATELY BUT IN SERIES OF 3 OR 4 PIECES DEPENDING ON THE MANDREL TYPE / BITTE: DIE WEICHEN KLEMMEN KÖNNEN NICHT EINZELN BESTELLT WERDEN, NUR IM SET VON 3 RESP. 4 STÜCKEN, ABHÄNGIG VON TYP DER SPINDEL / ANNOTATION: LES MORS TENDRES DOIVENT ÊTRE COMMANDES SEULEMENT EN JEUX DE 3 OU 4 PIÈCES SELON LE GENRE DU MANDRIN

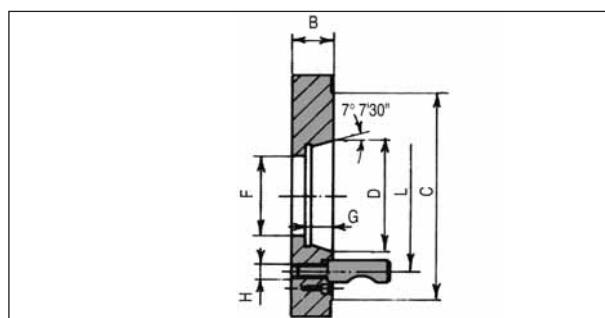

ASA B 5.9 TIPO/TYP D1 CAMLOCK (DIN 55029) / TYPE D1 CAMLOCK (DIN 55029) / TYPE D1 CAMLOCK (DIN 55029)

GRAND. CONO CONE SIZE KEGEL CÔNE	B	C	D	F	G	H	L	N. PERNI CAMLOCK CAMLOCK PINS N. N. BOLZEN CAMLOCK N. GOUJONS CAMLOCK	Ø A								
									160	200	250	270	315	400	500	630	
4"	39	120	63,51	60,7	13	7/16-20	82,55	3 - Ø 15,87	FLC160.000.04	FLC200.000.04	FLC250.000.04						
5"	39	140	82,56	79,4	16	1/2-20	104,8	6 - Ø 19,05	FLC160.000.05	FLC200.000.05	FLC250.000.05	FLC270.000.05	FLC315.000.05				
6"	42	180	106,37	103	17	5/8-18	133,4	6 - Ø 22,22		FLC200.000.06	FLC250.000.06	FLC270.000.06	FLC315.000.06	FLC400.000.06	FLC500.000.06		
8"	45	220	139,72	135,7	19	3/4-16	171,4	6 - Ø 25,4			FLC250.000.08	FLC270.000.08	FLC315.000.08	FLC400.000.08	FLC500.000.08	FLC630.000.08	
11"	52	290	196,87	192,5	21	7/8-14	235	6 - Ø 30,16					FLC315.000.11	FLC400.000.11	FLC500.000.11	LC630.000.11	
15"	55	403	285,77	281	23	1"-14	330,2	6 - Ø 34,91							FLC500.000.15	FLC630.000.15	

Serie FLD-FLA

FLANGE IN GHISA PER AUTOCENTRANTI
CAST IRON FLANGES FOR SELF-CENTERING CHUCKS
GUSSFLANSCH FÜR SPANNFUTTER
BRIDE EN FONTE POUR PLATEAU À CENTRAGE

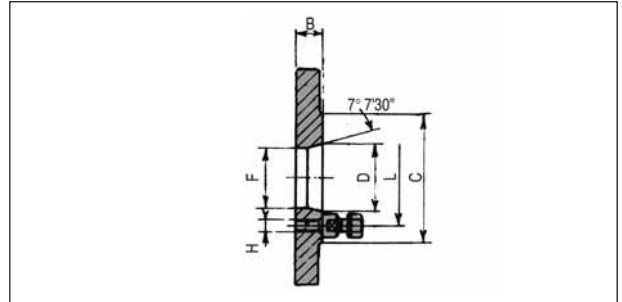

CON VITE PRIGIONIERA E DADO (DIN 55022 - DIN 55027) / STUD BOLT AND NUT/TYPE (DIN 55022 - DIN 55027) MIT STIFTSCHRAUBE UND BOLZEN / TYPE (DIN 55022 - DIN 55027) AVEC BOULONS PRISONNIERS ET ECROU (DIN 55022 - DIN 55027)

GRAND. CONO CONE SIZE KEGEL CÔNE	B	C	D	F	H	L	N. VITE PRIGION. SCREW STUD N. N. BOLZEN STIFTSCHRAUBE N. BOULONS PRISONNIERS	Ø A												
								125	160	200	250	270	315	350	400	500	630			
3"	39	98	53,98	51,2	M10	75	3	FLD125.000.03												
4"	39	120	63,52	60,7	M10	85	3		FLD160.000.04	FLD200.000.04	FLD250.000.04									
5"	39	140	82,57	79,4	M10	104,8	4		FLD160.000.05	FLD200.000.05	FLD250.000.05	FLD270.000.05	FLD315.000.05							
6"	42	180	106,39	103	M12	133,4	4			FLD200.000.06	FLD250.000.06	FLD270.000.06	FLD315.000.06	FLD350.000.06	FLD400.000.06					
8"	45	220	139,73	135,7	M16	171,4	4				FLD250.000.08	FLD270.000.08	FLD315.000.08	FLD350.000.08	FLD400.000.08					
11"	52	290	196,88	192,5	M20	235	6						FLD315.000.11	FLD350.000.11	FLD400.000.11	FLD500.000.11				
15"	55	403	285,8	281	M24	330,2	6													FLD630.000.15

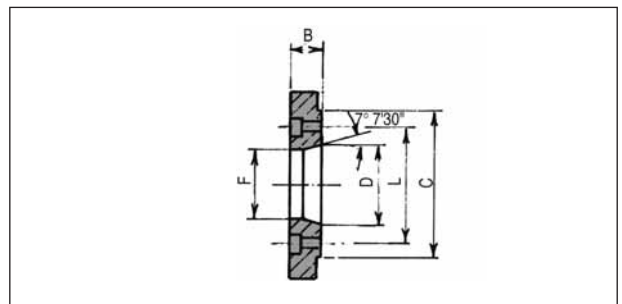

ASA B 5.9 TIPO CON FORI PASSANTI (DIN 55026 - DIN 55021)/TYPE A2 WITH THROUGH HOLES (DIN 55026 - DIN 55021) TYPE DIN 55026 - DIN 55021 MIT DURCHGANGSLOCH/TYPE DIN 55026 - DIN 55021 AVEC TROU DE PASSAGE

GRAND. CONO CONE SIZE KEGEL CÔNE	B	C	D	F	L	N. VITE PRIGION. SCREW STUD N. N. BOLZEN STIFTSCHRAUBE N. BOULONS PRISONNIERS	Ø A													
							160	200	250	270	315	350	400	500	630					
4"	39	120	63,52	60,7	85	4	FLA160.000.04	FLA200.000.04												
5"	39	140	82,57	79,4	104,8	4	FLA160.000.05	FLA200.000.05	FLA250.000.05	FLA270.000.05										
6"	42	180	106,39	103	133,4	4/8		FLA200.000.06	FLA250.000.06	FLA270.000.06	FLA315.000.06	FLA350.000.06	FLA400.000.06	FLA500.000.06						
8"	45	220	139,73	135,7	171,4	8			FLA250.000.08	FLA270.000.08	FLA315.000.08	FLA350.000.08	FLA400.000.08	FLA500.000.08	FLA630.000.08					
11"	52	290	196,88	192,5	235	8					FLA315.000.11	FLA350.000.11	FLA400.000.11	FLA500.000.11	FLA630.000.11					
15"	55	403	285,6	281	330,2	8								FLA400.000.15	FLA500.000.15	FLA630.000.15				